

RHB340-6 TECHNICAL SPECIFICATIONS

SH#	RHB6-T40-E1
Cre. Date	29 Jul, 2010
Rev. Date	
Page	1 of 4

1. EXTERNAL DIMENSIONS

Unit: mm

- BA: Silenced Version – Adapter Mount

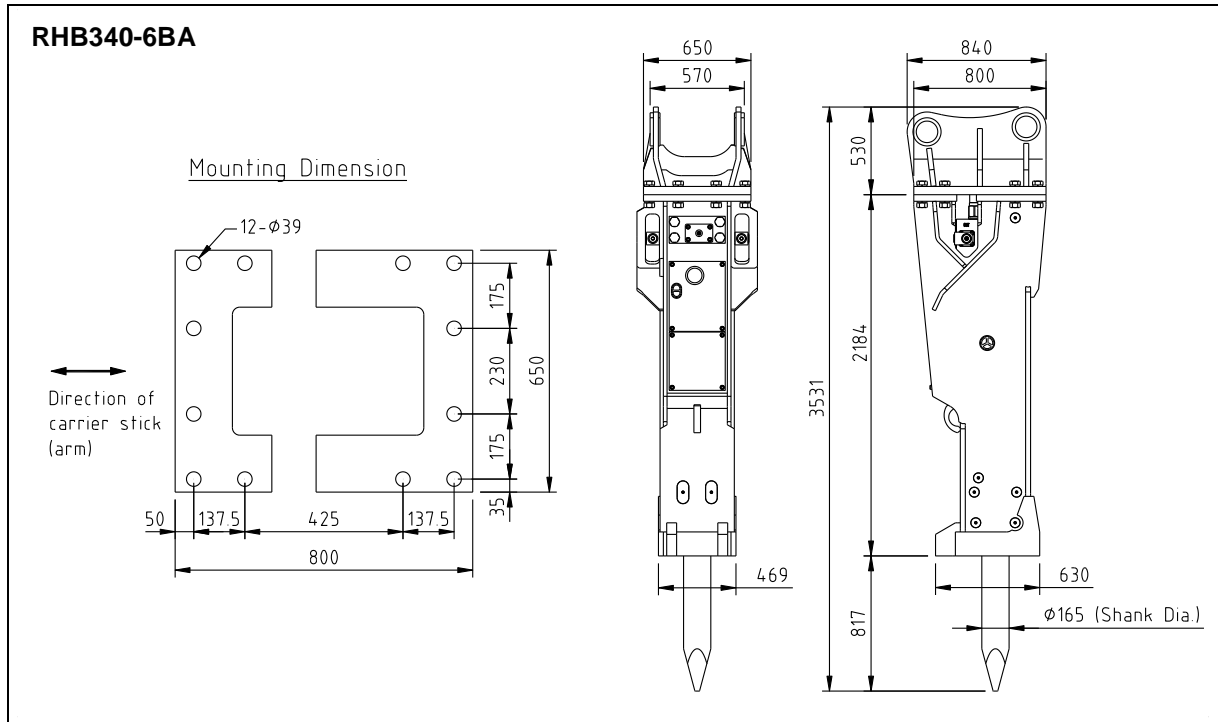

- Standard Mounting Adapter for BA version

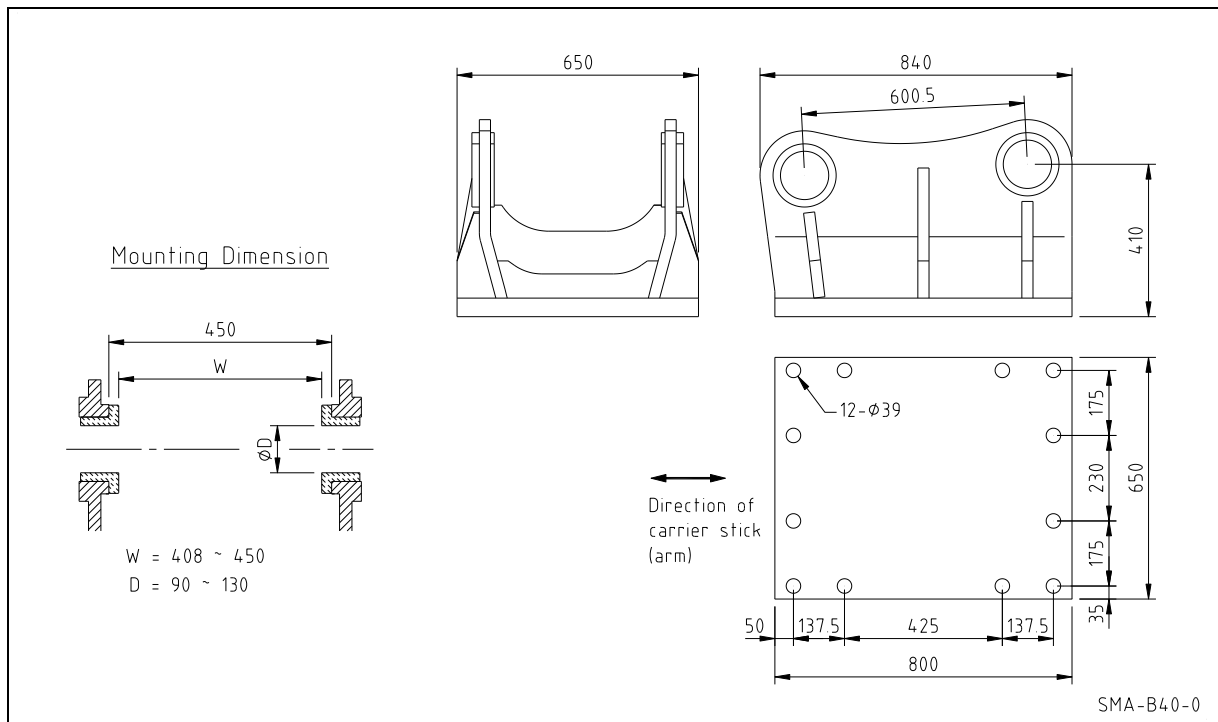

RHB340-6 TECHNICAL SPECIFICATIONS

SH#	RHB6-T40-E1
Cre. Date	29 Jul, 2010
Rev. Date	
Page	2 of 4

2. BASIC SPECIFICATIONS

Bracket Version	BA		
Available Option			
2-speed control	Std.		
Dust protector	Opt.		
Auto-greasing kit	Opt.		
Under-water operating kit	Opt.		
Working Weight ¹⁾	3,179 (7,008)		kg (lbs)
Weight without chisel and mounting adapter	2,539 (5,598)		kg (lbs)
Overall Length ²⁾	3,531 (139.0)		mm (in.)
Weight of components			
Power-cell	1,514	(3,338)	kg (lbs)
Chisel (standard)	200	(441)	kg (lbs)
Mounting adapter ³⁾	440	(970)	kg (lbs)
Required Oil Flow	200 ~ 280	(53 ~ 74)	lpm (gpm)
Operating Pressure	165 ~ 185	(2,400~2,700)	bar (psi)
Input Power (max.)	86		kW
Blow Frequency			
Low speed	330 ~ 450		bpm
High speed	420 ~ 600		bpm
Impact Energy			
Low speed	7,600	(5,605)	J (ft.lbf)
High speed	6,000	(4,425)	J (ft.lbf)
Tool (Chisel) Shank Diameter	165	(6.50)	mm (in.)
Applicable Carrier Weight			
Optimal range	32 ~ 40	(71 ~ 88)	t (klbs)
Available range	32 ~ 45	(71 ~ 99)	t (klbs)

Notes :

- 1) Total weight including standard tool, standard mounting adapter and spacers but excluding hydraulic hoses, fittings and mounting pins.
- 2) The length measured from the tool tip of the standard tool to the top of the breaker including mounting adapter.
- 3) Including standard mounting adapter, fasteners and spacers (for BA version).

RHB340-6 TECHNICAL SPECIFICATIONS

SH#	RHB6-T40-E1
Cre. Date	29 Jul, 2010
Rev. Date	
Page	3 of 4

3. INSTALLATION SPECIFICATIONS

Gas Charging Pressure ¹⁾			
Back-head (Piston accumulator) ²⁾	16 ~ 18	(230~260)	bar (psi)
High pressure accumulator	60	(870)	bar (psi)
Pressure Adjust Valve Setting ³⁾ (Number of turns open from the full-close)	3.0 ~ 3.5		turns
Hydraulic Piping			
Line size (min. internal diameter)	32	(1-1/4)	mm (in.)
Acceptable back pressure (max.) ⁴⁾	10	(150)	bar (psi)
Hose Connections of breaker			
Oil supply (IN) & return (OUT)	BSP 1-1/4" O-Ring Boss Female		
Air (A)	BSP 3/4" O-Ring Boss Female		
Pressure Relief (min.)	40 (600) + measured		max. operating pressure
Acceptable Hydraulic Oil			
Operating temperature ⁵⁾	-20 ~ +85	(-4 ~ +185)	°C (°F)
Viscosity	1000 ~ 10		cSt

Notes :

- 1) The prefill nitrogen gas pressure measured statically (breaker not operating) without down load on the tool at the stabilized gas temperature of +20 °C
- 2) The recommended value at the normal operating condition (supplied oil flow, oil temperature and viscosity, etc.)
- 3) The value which is set at the factory to obtain the nominal operating pressure at the middle value of oil flow and back-head gas pressure.
- 4) The maximum allowed oil pressure at the breaker's connection point to the return line (measured statically without the breaker)
- 5) The allowed temperature limits when using the oil of viscosity grade 46

4. BREAKING PERFORMANCE (per 8-hour shift)

Unit : m³ / 8hrs (yd³ / 8hrs)

Reinforced Concrete (t=30cm)	400 ~ 750	(523 ~ 981)
Non-reinforced Concrete (t=30cm)	550 ~ 1,050	(719 ~ 1,373)
Reducing oversize boulders	700 ~ 1,600	(916 ~ 2,093)
Quarrying (medium hard rock)	170 ~ 350	(222 ~ 458)



Notes :

- These figures are intended as a guideline only and varies according to the type of the material to be broken, the carrier's condition, the operator's skill, the place of usage, etc.

RHB340-6 TECHNICAL SPECIFICATIONS

SH#	RHB6-T40-E1
Cre. Date	29 Jul, 2010
Rev. Date	
Page	4 of 4

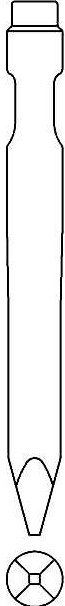
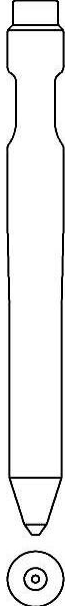
5. AVAILABLE TOOLS (CHISELS)

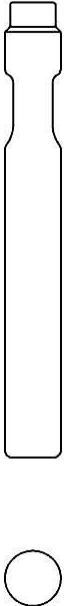
Shank Diameter	165 (6.50) mm (in.)				
	TYPE OF TOOL :				
	Moil Wedge (Pyramid)	Moil Point (Conical)	Flat Wedge –Horizontal (Cross-cut)	Flat Wedge –Vertical (Inline-cut)	Flat End (Blunt)
Tool Diameter ¹⁾	155 (6.10)	155 (6.10)	165 (6.50)	165 (6.50)	165 (6.50) mm (in.)
Tool Length	1450 (57)	1450 (57)	1450 (57)	1450 (57)	1300 (51) mm (in.)
Tool Weight	200 (441)	199 (439)	215 (474)	215 (474)	195 (430) kg (lbs)
Tool Shape					

Notes :

1) The diameter of the tool portion outside the breaker body

- Other special designs are also available on request.

RHB350-6 TECHNICAL SPECIFICATIONS

SH#	RHB6-T50-E1
Cre. Date	29 Jul, 2010
Rev. Date	
Page	1 of 4

1. EXTERNAL DIMENSIONS

Unit: mm

- **BA:** Silenced Version – Adapter Mount

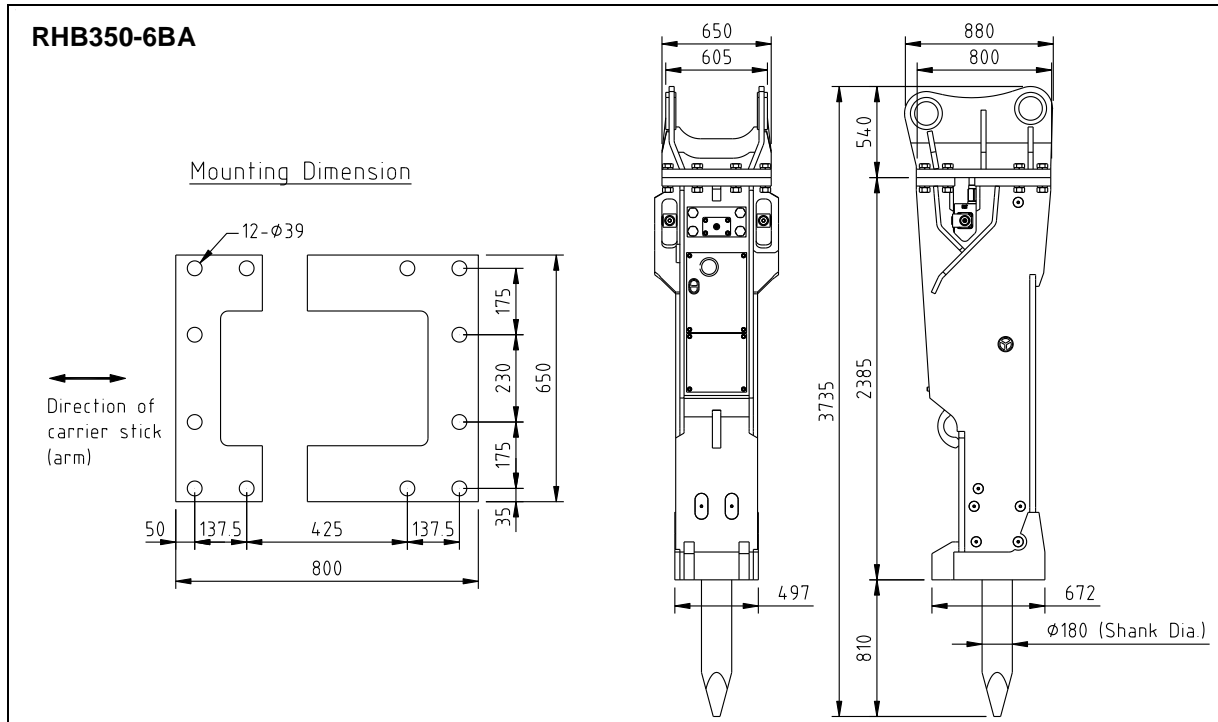

- **Standard Mounting Adapter for BA version**

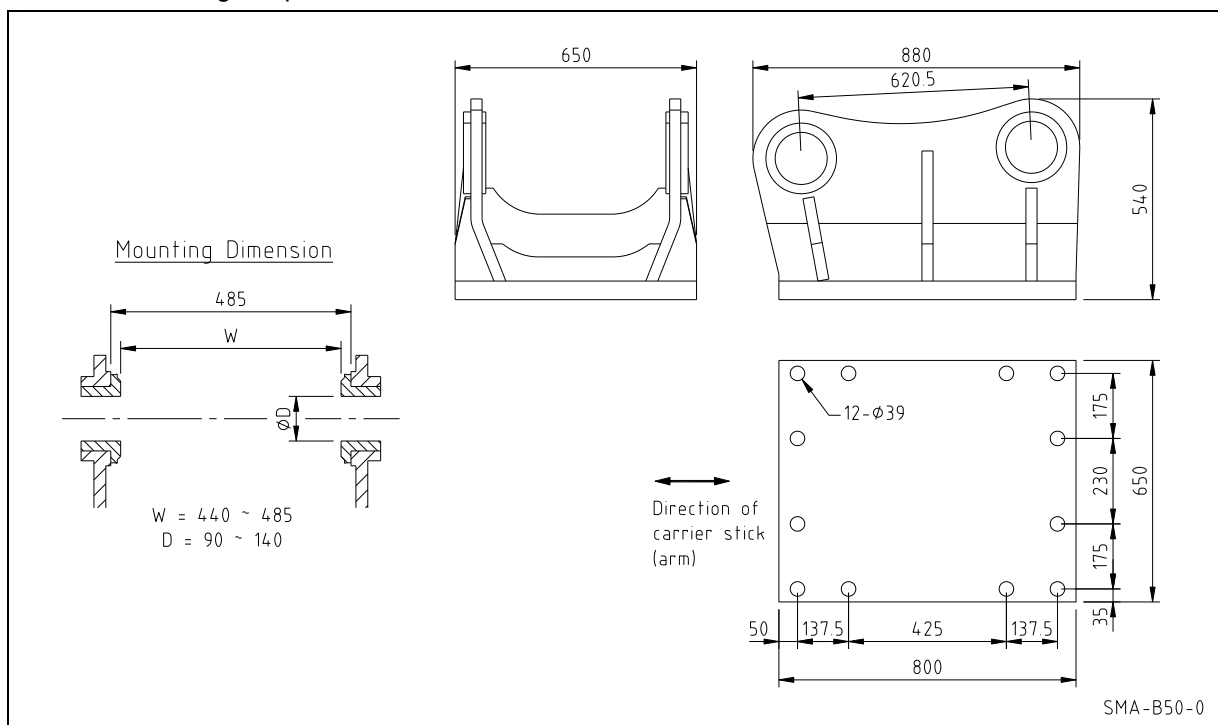

RHB350-6 TECHNICAL SPECIFICATIONS

SH#	RHB6-T50-E1
Cre. Date	29 Jul, 2010
Rev. Date	
Page	2 of 4

2. BASIC SPECIFICATIONS

Bracket Version	BA		
Available Option			
2-speed control	Std.		
Dust protector	Opt.		
Auto-greasing kit	Opt.		
Under-water operating kit	Opt.		
Working Weight ¹⁾	3,890 (8,576)		kg (lbs)
Weight without chisel and mounting adapter	3,175 (7,000)		kg (lbs)
Overall Length ²⁾	3,735 (147.0)		mm (in.)
Weight of components			
Power-cell	1,875	(4,134)	kg (lbs)
Chisel (standard)	265	(584)	kg (lbs)
Mounting adapter ³⁾	450	(992)	kg (lbs)
Required Oil Flow	230 ~ 330	(60 ~ 87)	lpm (gpm)
Operating Pressure	165 ~ 185	(2,400~2,700)	bar (psi)
Input Power (max.)	102		kW
Blow Frequency			
Low speed	250 ~ 370		bpm
High speed	350 ~ 500		bpm
Impact Energy			
Low speed	10,400	(7,670)	J (ft.lbf)
High speed	7,900	(5,827)	J (ft.lbf)
Tool (Chisel) Shank Diameter	180	(7.09)	mm (in.)
Applicable Carrier Weight			
Optimal range	40 ~ 60	(88 ~ 132)	t (klbs)
Available range	40 ~ 70	(88 ~ 154)	t (klbs)

Notes :

- 1) Total weight including standard tool, standard mounting adapter and spacers but excluding hydraulic hoses, fittings and mounting pins.
- 2) The length measured from the tool tip of the standard tool to the top of the breaker including mounting adapter.
- 3) Including standard mounting adapter, fasteners and spacers (for BA version).

RHB350-6 TECHNICAL SPECIFICATIONS

SH#	RHB6-T50-E1
Cre. Date	29 Jul, 2010
Rev. Date	
Page	3 of 4

3. INSTALLATION SPECIFICATIONS

Gas Charging Pressure ¹⁾			
Back-head (Piston accumulator) ²⁾	16 ~ 18	(230~260)	bar (psi)
High pressure accumulator	60	(870)	bar (psi)
Pressure Adjust Valve Setting ³⁾ (Number of turns open from the full-close)	3.0 ~ 3.5		turns
Hydraulic Piping			
Line size (min. internal diameter)	32	(1-1/4)	mm (in.)
Acceptable back pressure (max.) ⁴⁾	10	(150)	bar (psi)
Hose Connections of breaker			
Oil supply (IN) & return (OUT)	BSP 1-1/2" O-Ring Boss Female		
Air (A)	BSP 3/4" O-Ring Boss Female		
Pressure Relief (min.)	40 (600) + measured max. operating pressure		
Acceptable Hydraulic Oil			
Operating temperature ⁵⁾	-20 ~ +85	(-4 ~ +185)	°C (°F)
Viscosity	1000 ~ 10		cSt

Notes :

- 1) The prefill nitrogen gas pressure measured statically (breaker not operating) without down load on the tool at the stabilized gas temperature of +20 °C
- 2) The recommended value at the normal operating condition (supplied oil flow, oil temperature and viscosity, etc.)
- 3) The value which is set at the factory to obtain the nominal operating pressure at the middle value of oil flow and back-head gas pressure.
- 4) The maximum allowed oil pressure at the breaker's connection point to the return line (measured statically without the breaker)
- 5) The allowed temperature limits when using the oil of viscosity grade 46

4. BREAKING PERFORMANCE (per 8-hour shift)

Unit : m³ / 8hrs (yd³ / 8hrs)

Reinforced Concrete (t=30cm)	450 ~ 900	(589 ~ 1,177)
Non-reinforced Concrete (t=30cm)	650 ~ 1,300	(850 ~ 1,700)
Reducing oversize boulders	800 ~ 1,900	(1,046 ~ 2,485)
Quarrying (medium hard rock)	220 ~ 450	(288 ~ 589)



Notes :

- These figures are intended as a guideline only and varies according to the type of the material to be broken, the carrier's condition, the operator's skill, the place of usage, etc.

RHB350-6 TECHNICAL SPECIFICATIONS

SH#	RHB6-T50-E1
Cre. Date	29 Jul, 2010
Rev. Date	
Page	4 of 4

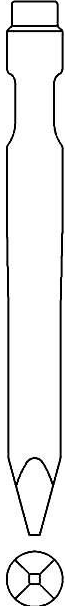
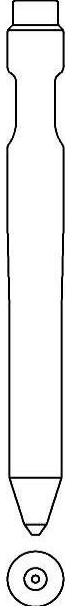
5. AVAILABLE TOOLS (CHISELS)

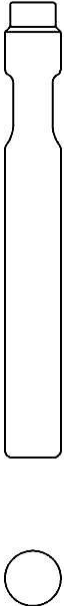
Shank Diameter	180 (7.09) mm (in.)				
	TYPE OF TOOL :				
	Moil Wedge (Pyramid)	Moil Point (Conical)	Flat Wedge –Horizontal (Cross-cut)	Flat Wedge –Vertical (Inline-cut)	Flat End (Blunt)
Tool Diameter ¹⁾	170 (6.69)	170 (6.69)	180 (7.09)	180 (7.09)	180 (7.09) mm (in.)
Tool Length	1600 (63)	1600 (63)	1600 (63)	1600 (63)	1450 (57) mm (in.)
Tool Weight	265 (584)	263 (580)	280 (617)	280 (617)	255 (562) kg (lbs)
Tool Shape					

Notes :

1) The diameter of the tool portion outside the breaker body

- Other special designs are also available on request.